

Sechskantschraube

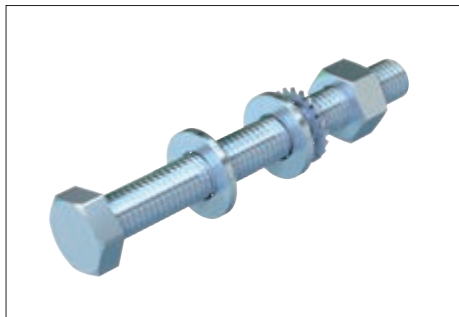

Sechskantschraube zur universellen Befestigung von Konstruktionsbauteilen.

Typ	Abmes- sung mm	Maß L mm	Maß d mm	SW mm	Verp. Stück	Gewicht kg/100 St.	Art.-Nr.
SKS 10X80 F	M10x80	80	10	17	20	7,700	6418 25 0
SKS 10X90 F	M10x90	90	10	17	20	7,800	6418 25 2
SKS 10X120 F	M10x120	120	10	17	20	13,500	3160 79 3

St Stahl **F** feuerverzinkt

